

ADVANCED FLOW SYSTEMS

HULIOT HT SYSTEM

PP Abwasserrohre
und Formstücke

Push-Fit polypropylene
Waste Water System

www.huliot.com

Tel : 77 77 24 25

HEATAIRCON

LTD



ADVANCED FLOW
SYSTEMS



Abflussrohre und Formstücke / Drainage pipes and fittings

- Verlegefreundlich - kein Schweißen oder Kleben erforderlich
- Korrosionsbeständig
- Schwerentflammbar
- Heißwasserbeständiges Rohrsystem – bis zu up 95°C
- 100% recyclebar
- Qualitätsgarantie – ISO 9001:2008
- Easy to install – no welding or gluing required
- Corrosion resistant
- Flame retardant material
- Hot water resistance up to 95°C.
- 100% recyclable
- Quality guarantee ISO 9001:2008



■ Beschreibung

Polypropylen (PP), hergestellt nach DIN EN 1451-1 bzw. ISO 7671:2003, heißwasserbeständig, dauerhaft schwer entflammbar nach DIN EN 4102 B1.

■ Anwendung

Entwässerung innerhalb von Gebäuden als
- Schmutzwasserleitung
- Regenwasserleitung
- Lüftungsleitung

■ Farbe

Staubgrau RAL 7037, halogen- und cadmiumfrei.

■ Dichtung

Werksseitig eingelegter Lippendichtring.

■ Chemische Beständigkeit

Ableitung von aggressiven Medien im Bereich pH 2 bis pH 12.

■ Kennzeichnung - Rohre und Formteile

Dauerhafte Kennzeichnung mit Herstellerzeichen, Nennweite, Normenbezeichnung (DIN EN 1451-1), Fertigungsdatum und handelsname – HULIOT.

■ Description

Polypropylene (PP), produced according to EN 1451-1 and ISO 7671:2003 respectively, resistant to hot water, permanent low inflammability as per EN 4102 B1.

■ Application

Building drainage as
- Waste water pipe
- Rainwater pipe
- Ventilation pipe

■ Colour

Dusty grey RAL 7037, halogen and cadmium-free.

■ Seal

Factory inlaid lip seal.

■ Chemical resistance

Discharge of aggressive media in the range of pH 2 to pH 12.

■ Marking Pipes and fittings

Permanent marking with manufacturer label, nominal diameter, EN standard (DIN EN 1451-1), date of manufacture and manufacturer's commercial name – HULIOT.



Abflussrohre und Formstücke / Drainage pipes and fittings

Mechanisch und Termisch Eigenschaften

Mechanical and thermal properties

Eigenschaft Property	Messmethode Measuring method		Symbol	WERT Value
Dichte (g/cm³) Density (g/cm ³)	DIN 53479	ISO 1183	ρ	0.95
Kerbschlagzähigkeit (20°C / kJ/m²) Notch impact resistance (at 20°C / kJ/m ²)	DIN 53453	ISO 179	ak	6.86
Grenzbiegespannung (N/mm²) Limited bending stress (N/mm ²)	DIN 53452		σ _{bG}	43.14
Streckbiegespannung (N/mm²) Yield stress (N/mm ²)			σ _s	33.0
Reißfestigkeit (N/mm²) Tear resistance (N/mm ²)	DIN 43452	ISO 527-2/50	σ _R	39.22
Reißdehnung (%) Elongation at tear (%)			ε _R	800
Elastizitätsmodul (N/mm²) Modulus of elasticity (N/mm ²)	DIN 53457		E	1275
Vicat-Erweichungspunkt (°C) Vicat softening point (°C)	DIN 53460	ISO 306-1	VSP/A	155-162
Wärmeleitfähigkeit (W/Km) Thermal conductivity (W/Km)	DIN 52162		λ	0.22
Linearer Wärmeausdehnungskoeffizient (°C⁻¹) Linear coefficient of thermal expansion (°C ⁻¹)	DIN VDE 0304-1-4		α	1.2·10 ⁻³

DN (OD)	S(mm)	t (mm)	Kg/m	D (mm)
40	1.8	54.9	0.22	53
50	1.8	55.6	0.28	63
75	1.9	63.4	0.42	88
110	2.7	74.20	0.87	125
125	3.1	82	1.10	143
160	3.9	90	2.37	181

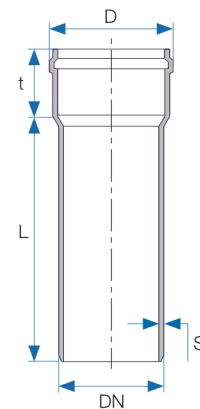



HT Rohre / HT Pipes

HTEM Rohr-Passlängen / HTEM Single socket pipe (push-fit)

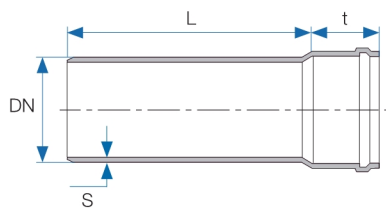

Art-nr. Art. No.	DN Ø mm	S	t	L mm	Stückgewicht Kg Unit weight Kg	Verpackung Packaging
54040015	40	1.8	49	150	0.03	132/3168
54040025		1.8	49	250	0.05	132/3168
54040050		1.8	49	500	0.10	30/750
54040100		1.8	49	1000	0.20	10/600
54040150		1.8	49	1500	0.30	10/200
54040200		1.8	49	2000	0.40	10/200
54040300		1.8	49	3000	0.60	10/200
54040400		1.8	49	4000	0.80	10/200
54050015	50	1.8	51	150	0.04	60
54050025		1.8	51	250	0.06	40/1000
54050050		1.8	51	500	0.13	20/400
54050100		1.8	51	1000	0.26	20/500
54050150		1.8	51	1500	0.39	10/200
54050200		1.8	51	2000	0.52	10/200
54050250		1.8	51	3000	0.77	10/200
54050300		1.8	51	4000	1.03	10/200
54075015	75	1.9	54	150	0.06	10/500
54075025		1.9	54	250	0.10	8/400
54075050		1.9	54	500	0.20	4/288
54075100		1.9	54	1000	0.40	2/168
54075150		1.9	54	1500	0.60	4/100
54075200		1.9	54	2000	0.80	4/100
54075300		1.9	54	3000	1.21	1/100
54075400		1.9	54	4000	1.61	1/100
54110015	110	2.7	59	150	0.13	10/450
54110025		2.7	59	250	0.21	8/288
54110050		2.7	59	500	0.42	4/288
54110100		2.7	59	1000	0.84	4/160
54110150		2.7	59	1500	1.26	450
54110200		2.7	59	2000	1.68	4/50
54110300		2.7	59	3000	2.53	63
54110400		2.7	59	4000	3.37	63



HT Rohre / HT Pipes

HTEM Rohr-Passlängen / HTEM Single socket pipe (push-fit)

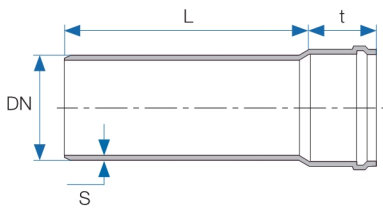

Art-nr. Art. No.	DN Ø mm	S	t	L mm	Stückgewicht Kg Unit weight Kg	Verpackung Packaging
54125015	125	3.1	62	150	0.14	8
54125025		3.1	62	250	0.24	8
54125050		3.1	62	500	0.47	8
54125100		3.1	62	1000	0.95	8
54125150		3.1	62	1500	1.42	36
54125200		3.1	62	2000	1.89	36
54125300		3.1	62	3000	2.84	36
54125400		3.1	62	4000	3.78	36

HTGL Rohr ohne Muffe / HTGL Plain ended pipe

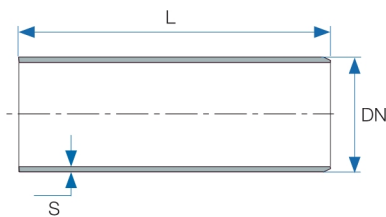

Art-nr. Art. No.	DN Ø mm	S	L mm	Stückgewicht Kg Unit weight Kg	Verpackung Packaging
64032400	32	1.8	4000	0.644	300
64041400	40	1.8	4000	0.804	300
64051400	50	1.8	4000	1.032	200
64075400	75	1.9	4000	1.608	100
64110400	110	2.7	4000	3.368	63
64125400	125	3.1	4000	3.780	36



Formstücke / Fittings

HTB Bogen / HTB Bend

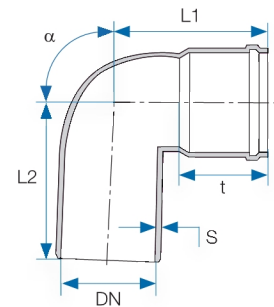
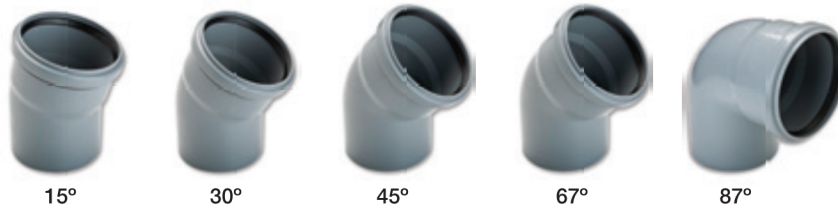

α	Art-nr. Art. No.	DN \varnothing mm	S	t	L1 mm	L2 mm	Stückgewicht Kg Unit weight Kg	Verpackung Packaging
15°	40010150	40	1.8	50	67	62	0.033	20/960
	40020150	50	1.8	47	60	79	0.043	20/960
	40030150	75	1.9	54	89	68	0.064	20/480
	40040150	110	2.7	61	85	67	0.139	32/768
	40050150	125	3.1	61	104	62	0.215	20/160
30°	40010350	40	1.8	50	67	62	0.034	20/960
	40020350	50	1.8	47	60	79	0.046	20/960
	40030350	75	1.9	54	89	68	0.078	20/480
	40040350	110	2.7	61	87	79	0.137	32/768
	40050350	125	3.1	61	97	81	0.234	20/160
45°	40010460	40	1.8	50	67	62	0.034	130/6240
	40020460	50	1.8	47	60	79	0.046	80/3840
	40030460	75	1.9	54	89	68	0.070	55/1540
	40040460	110	2.7	57	118	111	0.165	28/672
	40050460	125	3.1	61	98	96	0.271	20/160
67°	40010660	40	1.8	50	77	75	0.037	20/960
	40020660	50	1.8	47	80	80	0.052	20/960
	40030660	75	1.9	54	101	98	0.092	20/480
	40040660	110	2.7	61	102	100	0.110	20/240
87°	40010860	40	1.8	50	77	75	0.038	110/5280
	40020860	50	1.8	47	80	80	0.052	70/3360
	40030860	75	1.9	54	101	98	0.089	45/1260
	40040860	110	2.7	57	129	120	0.201	24/576
	40050860	125	3.1	61	137	138	0.329	10/120



Formstücke / Fittings

■ HTEA – Einfach-Abzweig

HTEA – Single Branch

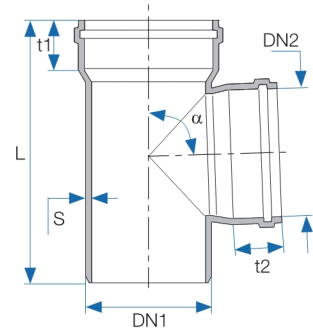

Art-nr. Art. No.	α	Markierung Marking	DN1 \varnothing mm	DN2 \varnothing mm	S	t1	t2	L mm	Stückgewicht Kg Unit weight Kg	Verpackung Packaging
40611440	45°	40/40/45	40	40	1.8	43	43	160	0.068	20/960
40621440		50/40/45	50	40	1.8	48	48	122	0.060	20/960
40622460		50/50/45	50	50	1.8	50	50	176	0.091	20/480
40632460		75/50/45	75	50	1.9	51	48	133	0.113	36/1008
40633460		75/75/45	75	75	1.9	51	51	171	0.137	32/768
40642460		110/50/45	110	50	2.7	61	48	144	0.210	22/528
40643460		110/75/45	110	75	2.7	59	49	174	0.307	20/160'
40644460		110/110/45	110	110	2.7	59	59	196	0.345	10/240
40654460		125/110/45	125	110	3.1	60	59	238	0.459	5/60
40655460		125/125/45	125	125	3.1	60	60	238	0.612	5/60
40611660	67°	40/40/67	40	40	1.8	46	46	146	0.063	20/960
40621660		50/40/67	50	40	1.8	48	46	115	0.078	20/480
40622660		50/50/67	50	50	1.8	48	48	121	0.086	20/480
40632660		75/50/67	75	50	1.9	51	48	140	0.123	20/480
40633660		75/75/67	75	75	1.9	51	51	140	0.154	20/240
40642660		110/50/67	110	50	2.7	57	50	187	0.229	20/240
40643660		110/75/67	110	75	2.7	57	49	210	0.262	20/160
40644660		110/110/67	110	110	2.7	59	59	165	0.370	10/120
40611860	87°	40/40/87	40	40	1.8	46	46	146	0.050	20/960
40621860		50/40/87	50	40	1.8	48	46	115	0.066	40/1920
40622860		50/50/87	50	50	1.8	48	48	121	0.066	40/1920
40632860		75/50/87	75	50	1.9	51	48	140	0.103	35/980
40633860		75/75/87	75	75	1.9	51	51	140	0.110	34/952
40642860		110/50/87	110	50	2.7	57	50	187	0.201	25/600
40643860		110/75/87	110	75	2.7	57	49	210	0.244	20/160
40644860		110/110/87	110	110	2.7	57	57	187	0.283	12/336
40652860		125/50/87	125	50	3.1	60	46	210	0.370	11/308
40654860		125/110/87	125	110	3.1	64	54	190	0.399	8/224
40655860		125/125/87	125	125	3.1	60	60	210	0.430	8/224



Formstücke / Fittings

HTDA - Doppel-Abzweig

HTDA - Double branch

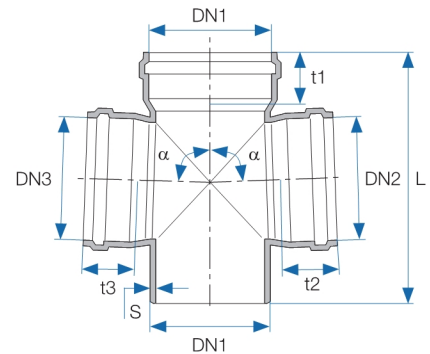

Art-nr. Art. No.	α	Markierung Marking	DN1 \varnothing mm	DN2 \varnothing mm	DN3 \varnothing mm	S	t 1	t 2	t 3	L mm	Stückgewicht Kg Unit weight Kg	Verpackung Packaging
41022460	45°	50/50/50/45	50	50	50	1.8	51	51	51	137	0.104	20/480
41033450		75/75/75/45	75	75	75	1.9	57	57	57	152	0.182	20/240
41044450		110/110/110/45	110	110	110	3.2	62	62	62	228	0.798	9/144
41022860	87°	50/50/50/87	50	50	50	1.8	51	51	51	115	0.104	20/480
41033860		75/75/75/87	75	75	75	1.9	57	57	57	149	0.182	16/448
41042860		110/50/50/87	110	50	50	2.7	58	48	48	188	0.247	10/280
41044860		110/110/110/87	110	110	110	2.7	58	58	58	194	0.366	8/224
41052860		125/50/50/87	125	50	50	3.1	59	45	45	210	0.390	24/192

HTED Eckabzweig

HTED - Double corner branch

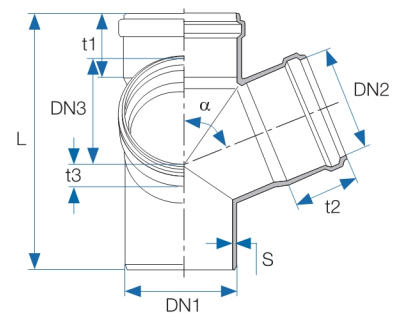

Art-nr. Art. No.	α	Markierung Marking	DN1 \varnothing mm	DN2 \varnothing mm	DN3 \varnothing mm	S	t 1	t 2	t 3	L mm	Stückgewicht Kg Unit weight Kg	Verpackung Packaging
41242850	87°	110/50/50/87	110	50	50	2.7	58	45	45	128	0.247	20/480
41244850		110/110/110/87	110	110	110	2.7	58	58	58	197	0.461	6/168
41252860		125/50/50/87	125	50	50	3.1	59	45	47	209	0.390	24/192



Formstücke / Fittings

■ HTR – Reduktion, exentrisch, kurz

HTR – Reducer, eccentric, short

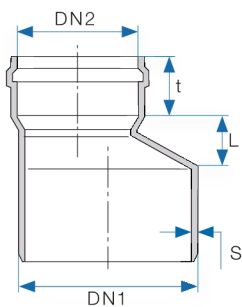

Art-nr. Art. No.	Markierung Marking	DN1 Ø mm	DN2 Ø mm	S	t	L mm	Stückgewicht Kg Unit weight Kg	Verpackung Packaging
42121060	50/40	50	40	1.8	42	21	0.034	120/5760
42132050	75/50	75	50	1.9	44	28	0.053	60/2880
42142050	110/50	110	50	2.7	52	47	0.112	32/768
42143050	110/75	110	75	2.7	51	28	0.106	60/1440
42154060	125/110	125	110	3.1	56	19	0.173	20/240

■ HTRE - Reinigungsrohr

HTRE – Inspection-cleaning pipe

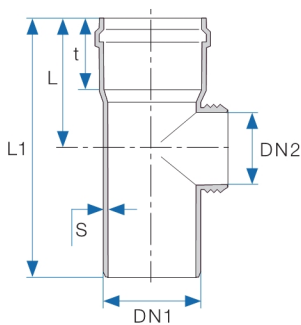

Art-nr. Art. No.	DN Ø mm	Reinigung Eintrag Ø Cleaning entry Ø	S	t	L1 mm	L mm	Stückgewicht Kg Unit weight Kg	Verpackung Packaging
49120050	50	45	1.8	49	84	168	0.092	20/480
49130050	75	45	1.9	45	87	180	0.161	20/480
49140060	110	98	2.7	61	124	252	0.266	15/420



Formstücke / Fittings

HT Ersatzdeckel für Reinigungsrohre

HT Replacement cover for inspection pipe



Art-nr. Art. No.	DN Ø mm	Stückgewicht Kg Unit weight Kg	Verpackung Packaging
41420060	50	0.015	550/26400
41430060	75	0.026	270/12960
41441260	100	0.046	48/7200

HTMM - Doppelmuffe / HTMM – Double socket

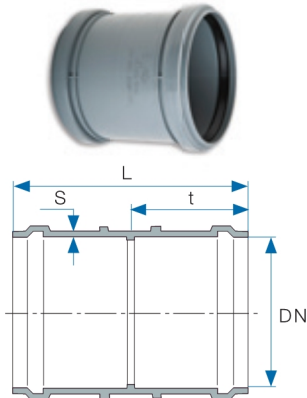

Art-nr. Art. No.	DN Ø mm	S	t	L mm	Stückgewicht Kg Unit weight Kg	Verpackung Packaging
41710050	40	1.7	50	103	0.028	20/960
41720050	50	1.7	51.5	105	0.040	60/2880
41730050	75	1.8	54.5	112	0.063	44/2112
41740250	110	2.5	63.5	130	0.134	32/896
41750060	125	2.8	80	185	0.245	20/160

HTL - Langmuffe / HTL – Long socket

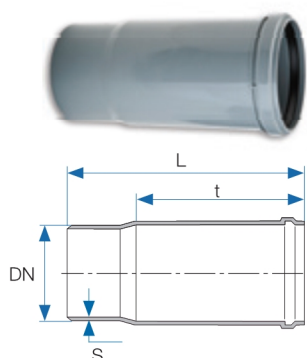

Art-nr. Art. No.	DN Ø mm	S	t	L mm	Stückgewicht Kg Unit weight Kg	Verpackung Packaging
42220050	50	1.8	150	210	0.071	20/480
42230050	75	1.9	159	224	0.117	20/480
42240050	110	2.7	180	254	0.230	16/448

HULIOT HT SYSTEM

PP Abwasserrohre und Formstücke
Push-Fit Polypropylene Waste Water System



Formstücke / Fittings

HTU - Überschiebmuffe / HTU – Coupler

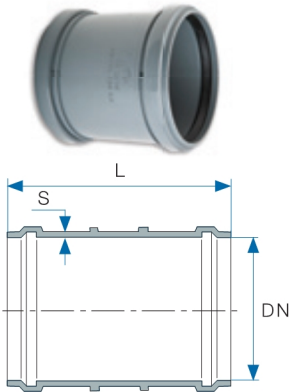

Art-nr. Art. No.	DN Ø mm	S	L mm	Stückgewicht Kg Unit weight Kg	Verpackung Packaging
42121060	75	1.8	112	0.081	20/480
42132050	110	2.5	130	0.134	32/896
42142050	125	2.8	185	0.213	20/160

HTM Muffenstopfen / HTM – Plug

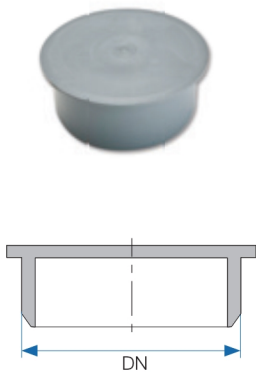

Art-nr. Art. No.	DN Ø mm	Stückgewicht Kg Unit weight Kg	Verpackung Packaging
41610040	40	0.010	300/14400
41620050	50	0.014	200/9600
41630050	75	0.027	140/6720
41640050	110	0.077	80/2240
41650060	125	0.089	20/480

Zubehör / Accessories

HT - Lippendichtung / HT – Lip seal

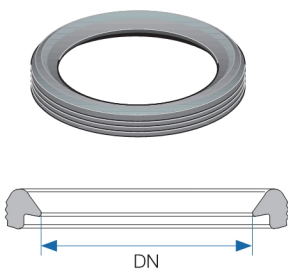

Art-nr. Art. No.	DN Ø mm	Stückgewicht Kg Unit weight Kg	Verpackung Packaging
47603241	32	0.003	3000
47610041	40	0.006	1890
47620041	50	0.007	1225
47630041	75	0.010	700
47640041	110	0.022	350
47650041	125	0.029	200



Tel : 77 77 24 25

HEATAIRCON

LTD

Tseriou 128 Ave,
2044 Nicosia, Cyprus

Tel : 00357 22314501
Fax : 00357 22312840

Email : info@heataircon.com.cy
Website : www.heataircon.com.cy



ADVANCED FLOW
SYSTEMS

HULIOT A.C.S Ltd.
Kibbutz Sde-Nehemia
Upper-Galile, 12145, ISRAEL
Tel: +972- 4-6946011, Fax: +972-4-6951444
info@huliot.com, www.huliot.com