

ADVANCED FLOW
SYSTEMS

**HULIOT
KG SYSTEM**

PVC Kanalrohrsystem
und Formstücke

Push-fit PVC Drainage
pipes and fittings

www.huliot.com

Tel : 77 77 24 25

HEATAIRCON
LTD



ADVANCED FLOW
SYSTEMS



Abflussrohre und Formstücke / Drainage pipes and fittings

- Verlegefreundlich - kein Schweißen oder Kleben erforderlich
- Ringsteifigkeit SN-4 für Normallast
- Ringsteifigkeit SN-8 für Hochlast
- Unempfindlich Gegenüber Bodensetzungen
- 100% recyclebar / Einhaltung der RoHS
- Qualitätsgarantie – ISO 9001:2008
- Easy to install – no welding or gluing required
- SN-4 ring stiffness for normal load
- SN-8 ring stiffness for high load
- Withstands subterranean movement
- 100% recyclable - RoHS Compatibility
- Quality guarantee - ISO 9001:2008



Abflussrohre und Formstücke Beschreibung

Kanalrohrsystem aus Polyvinylchlorid, hart, Ringsteifigkeit SN 4 und SN 8, hergestellt nach DIN EN 1401 bzw. ISO 4435.

Rohstoffe

Huliot's PVC-Rohre sind unter Verwendung organischer Basis Stabilisatoren (OBS) und sind frei von allen Metallen.

Farbe

Orange RAL 8023.

Dichtungselemente

Die Dichtheit der Verbindungen wird durch Dichtungselemente aus beständigen Elastomeren sichergestellt. Diese sind in der Sickennut angebracht. Die Dichtungseigenschaften bleiben auch bei Verformung oder Rohrumlenkung erhalten.

Kennzeichnung - Rohre und Formteile

Dauerhafte Kennzeichnung mit Herstellerzeichen, Nennweite, Normenbezeichnung Fertigungsdatum und handelsname – HULIOT.

Drainage pipes and fittings Description

Polyvinyl chloride drainage pipe system, unplasticized, SN 4 and SN 8 ring stiffness, manufactured according to EN 1401 and ISO 4435 respectively.

Materials

Huliot's PVC pipes are manufactured using organic-based stabilizers (OBS), and are free of all metals.

Colour

Orange RAL 8023.

Seal

Resistant elastomeric sealing elements are used to ensure connection tightness. They are fitted in the creased groove. The sealing properties are not affected by any pipe deformation or deflection.

Marking Pipes and fittings

Permanent marking with manufacturer label, nominal diameter, EN standard, date of manufacture and manufacturer's commercial name – HULIOT.



Abflussrohre und Formstücke / Drainage pipes and fittings

Mechanisch und Termisch Eigenschaften

Mechanical and thermal properties

Eigenschaft Property	Messmethode Measuring method		Symbol	WERT Value
Dichte (g/cm³) Density (g/cm ³)	DIN 53479	ISO 1183	ρ	1.39-1.40
Kerbschlagzähigkeit (20°C / kJ/m²) Notch impact resistance (at 20°C / kJ/m ²)	DIN 53453	ISO 179	a_k	3-4
Grenzbiegespannung (N/mm²) Limited bending stress (N/mm ²)	DIN 53452	-	σ_{bG}	95
Streckbiegespannung (N/mm²) Yield stress (N/mm ²)	DIN 43452	ISO 527-2/50	σ_s	55-60
Reißfestigkeit (N/mm²) Tear resistance (N/mm ²)			E	800
Elastizitätsmodul (N/mm²) Modulus of elasticity (N/mm ²)	DIN 53457	ISO 527	E	3000
Vicat-Erweichungspunkt (°C) Vicat softening point (°C)	DIN 53460	ISO 306-1	VSP/A	356
Wärmeleitfähigkeit (W/Km) Thermal conductivity (W/Km)	DIN 52162	-	λ	0.15
Linearer Wärmeausdehnungskoeffizient (°C⁻¹) Linear coefficient of thermal expansion (°C ⁻¹)	DIN VDE 0304-1-4	-	α	8X10 ⁻⁵
Wasseraufnahme (mg/cm²) Water absorption (mg/cm ²)	DIN 8061	-	-	<4

DN (OD)	S (mm)	t (mm)	Kg/m	D (mm)
110	3.2	66	1.48	127
125	3.2	68	1.68	144
160	4.0	84	2.87	182
200	4.9	106	4.39	225
250	6.2	128	6.96	287
315	7.7	162	11.02	355
400	9.8	194	20.75	445

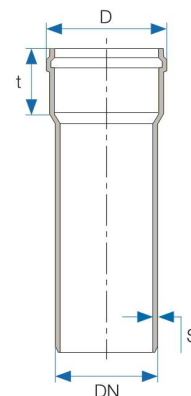

HULIOT KG SYSTEM

PVC Kanalrohrsystem und Formstücke
Push-fit PVC Drainage pipes and fittings system



KG Rohre / KG Pipes

■ KGEM – Rohr-Passlängen SN 4

KGEM – Single socket pipe (push-fit) SN 4

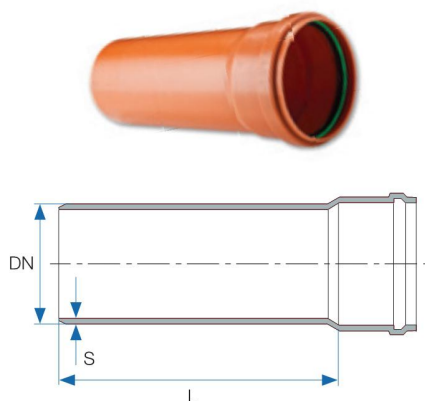

Art-nr. Art. No.	DN	S	L	Stückgewicht Kg Unit weight Kg	Verpackung Packaging
51110025	110	3.0	250	0.37	192
51110050	110	3.0	500	0.74	96
51110100	110	3.0	1,000	1.48	86
51110150	110	3.0	1,500	2.22	86
51110200	110	3.0	2,000	2.96	86
51110300	110	3.0	3,000	4.44	86
51110500	110	3.0	5,000	7.40	86
51125025	125	3.0	250	0.42	140
51125050	125	3.0	500	0.84	70
51125100	125	3.0	1,000	1.68	60
51125150	125	3.0	1,500	2.52	60
51125200	125	3.0	2,000	3.36	60
51125300	125	3.0	3,000	5.04	60
51125500	125	3.0	5,000	8.40	60
51160025	160	4.0	250	0.72	90
51160050	160	4.0	500	1.44	45
51160100	160	4.0	1,000	2.87	40
51160150	160	4.0	1,500	4.31	40
51160200	160	4.0	2,000	5.74	40
51160300	160	4.0	3,000	8.61	40
51160500	160	4.0	5,000	14.35	40
51200025	200	4.9	250	1.10	50
51200050	200	4.9	500	2.20	25
51200100	200	4.9	1,000	4.40	25
51200200	200	4.9	2,000	8.80	25
51200300	200	4.9	3,000	13.20	25
51200500	200	4.9	5,000	22.00	25
51250025	250	6.2	250	1.74	1
51250050	250	6.2	500	3.48	1
51250100	250	6.2	1,000	6.95	1
51250200	250	6.2	2,000	13.90	1
51250300	250	6.2	3,000	20.85	1
51250500	250	6.2	5,000	34.75	1

HULIOT KG SYSTEM

PVC Kanalrohrsystem und Formstücke
Push-fit PVC Drainage pipes and fittings system



KG Rohre / KG Pipes

KGEM – Rohr-Passlängen SN 8

KGEM – Single socket pipe (push-fit) SN 8

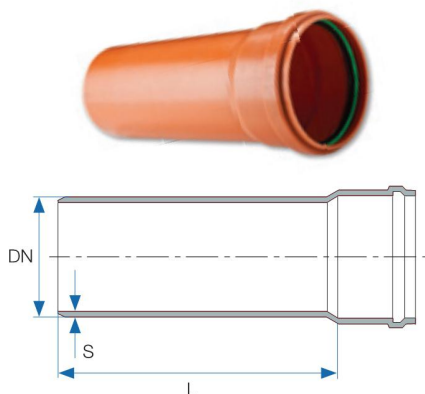

Art-nr. Art. No.	DN	S	L	Stückgewicht Kg Unit weight Kg	Verpackung Packaging
56110025	110	3.2	250	0.39	192
56110050	110	3.2	500	0.79	96
56110100	110	3.2	1,000	1.57	86
56110300	110	3.2	3,000	4.71	86
56110400	110	3.2	4,000	6.28	86
56125300	125	3.2	3,000	5.37	60
56125400	125	3.2	4,000	7.16	60
56160300	160	4.7	3,000	10.08	40
56160400	160	4.7	4,000	13.44	40
56200300	200	5.9	3,000	15.81	25
56200400	200	5.9	4,000	21.08	25
56250300	250	7.3	3,000	24.45	1
56250400	250	7.3	4,000	32.60	1
56315300	315	9.2	3,000	38.82	1
56355300	355	10.4	3,000	49.47	1
56400300	400	11.7	3,000	62.70	1

KGB Bogen / KGB Bend

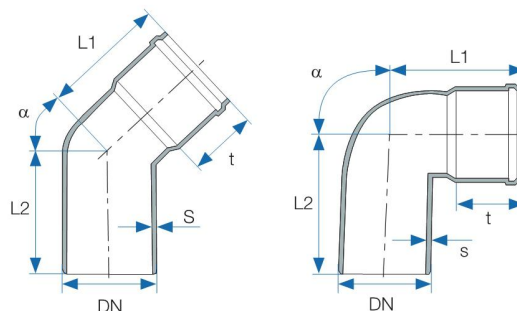

α	Art-nr. Art. No.	DN	S	t	L1	L2	Stückgewicht Kg Unit weight Kg	Verpackung Packaging
15°	43040150	110	3.2	56	122	74	0.29	300
	43050150	125	3.2	61	97	81	0.33	230
	43060150	160	4.0	70	94	105	0.62	110
	43080150	200	4.9	85	150	155	1.14	50
	43090150	250	6.2	102	219	158	3.50	24
	43031150	315	7.7	117	280	240	6.30	12

HULIOT KG SYSTEM

PVC Kanalrohrsystem und Formstücke
Push-fit PVC Drainage pipes and fittings system



Formstücke / Fittings

■ KGB Bogen / KGB Bend

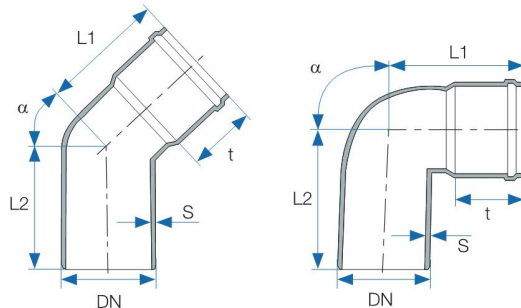

α	Art-nr. Art. No.	DN	S	t	L1	L2	Stückgewicht Kg Unit weight Kg	Verpackung Packaging
30°	43040350	110	3.2	56	122	74	0.32	270
	43050350	125	3.2	61	97	81	0.36	200
	43060350	160	4.0	68	98	99	0.68	100
	43080350	200	4.9	85	150	155	1.60	45
	43090350	250	6.2	102	219	158	3.70	24
	43031350	315	7.7	117	280	240	6.75	12
45°	43040450	110	3.2	56	122	74	0.34	250
	40020460	125	3.2	61	97	81	0.42	175
	43060450	160	4.0	77	145	116	0.74	90
	43080440	200	4.9	85	150	155	1.41	45
	43090440	250	6.2	102	219	158	3.00	24
	43031430	315	7.7	117	280	240	6.81	12
67°	43040650	110	3.2	56	122	74	0.37	225
	43050650	125	3.2	61	97	81	0.43	150
	43060650	160	4.0	68	98	99	0.80	75
	43080650	200	4.9	85	150	155	1.57	40
87°	43040850	110	3.2	56	118	122	0.44	200
	43050850	125	3.2	61	97	81	0.50	140
	43060850	160	4.0	77	185	162	0.95	70
	43080840	200	4.9	89	185	189	2.56	35
	43090840	250	6.2	102	310	310	3.80	18
	43031830	315	7.7	117	318	320	7.00	9

HULIOT KG SYSTEM

PVC Kanalrohrsystem und Formstücke
Push-fit PVC Drainage pipes and fittings system



Formstücke / Fittings

■ KGEA – Einfach-Abzweig / KGEA – Single Branch

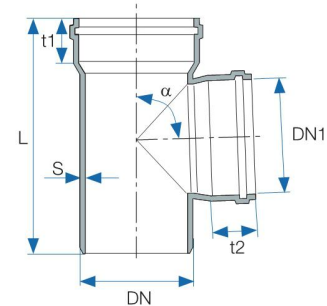

Art-nr. Art. No.	α	Markierung Marking	DN	DN1	S	t1	t2	L	Stückgewicht Kg Unit weight Kg	Verpackung Packaging	
43344450	45°	110/110/45	110	110	3.2	54	54	228	0.69	100	
43354450		125/110/45	125	110	3.2	62	54	238	0.76	70	
43355450		125/125/45	125	125	3.2	62	62	238	0.89	70	
43364450		160/110/45	160	110	4.0	69	54	317	1.17	51	
43365450		160/125/45	160	125	4.0	69	62	160	1.21	45	
43366450		160/160/45	160	160	4.0	68	68	390	1.67	36	
43384450		200/110/45	200	110	4.9	81	52	425	1.85	30	
43385450		200/125/45	200	125	4.9	81	62	425	2.04	32	
43386450		200/160/45	200	160	4.9	81	70	425	2.38	26	
43388450		200/200/45	200	200	4.9	82	82	480	3.76	20	
43398450		250/200/45	250	200	6.2	110	90	490	4.56	12	
43399450		250/250/45	250	250	6.2	110	110	490	6.15	8	
43344850		87°	110/110/87	110	110	3.2	55	55	242	0.55	120
43354850			125/110/87	125	110	3.2	64	55	210	0.64	126
43355850	125/125/87		125	125	3.2	64	60	210	0.70	108	
43364850	160/110/87		160	110	4.0	74	54	269	1.18	60	
43365850	160/125/87		160	125	4.0	74	60	250	1.07	60	
43366850	160/160/87		160	160	4.0	74	74	250	1.35	45	
43384850	200/110/87		200	110	4.9	81	54	320	1.66	38	
43385850	200/125/87		200	125	4.9	82	60	370	1.73	38	
43386850	200/160/87		200	160	4.9	82	70	370	2.01	32	
43388850	200/200/87		200	200	4.9	82	82	408	2.46	24	
43398850	250/200/87		250	200	6.2	110	90	493	3.73	14	
43399850	250/250/87		250	250	6.2	102	102	520	4.53	12	
43333830	315/315/87		315	315	7.7	123	123	473	8.45	6	
43349840	400/400/87		400	400	9.8	140	140	520	20.80	2	



Formstücke / Fittings

■ KGR – Reduktion, exentrisch, kurz

KGR – Reducer, eccentric, short

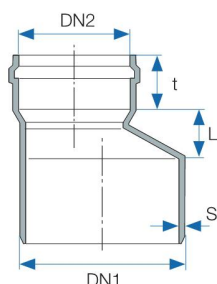

Art-nr. Art. No.	Markierung Marking	DN1	DN2	S	t	L	Stückgewicht Kg Unit weight Kg	Verpackung Packaging
43454040	125/110	125	110	3.2	56	19	0.28	300
43464040	160/110	160	110	4.0	50	40	0.48	250
43465040	160/125	160	125	4.0	69	34	0.49	240
43486040	200/160	200	160	4.9	79	35	0.85	130
43498040	250/200	250	200	6.2	80	45	2.45	54

■ KGRE - Reinigungsrohr

KGRE –Inspection-cleaning pipe

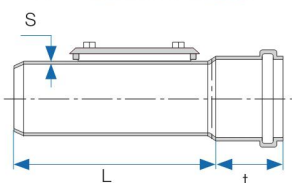

Art-nr. Art. No.	DN	Reinigung Eintrag Ø Cleaning entry Ø	S	t	L	Stückgewicht Kg Unit weight Kg	Verpackung Packaging
48140060	110	100	3.2	55	359	1.090	108
48150060	125	100	3.2	62	365	1.222	90
48160060	160	100	4.0	74	394	1.666	60
48180060	200	100	4.9	82	494	4.425	22

■ KGMM - Doppelmuffe / KGMM – Double socket

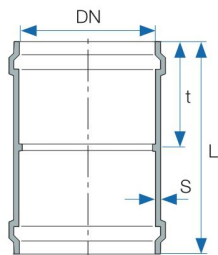

Art-nr. Art. No.	DN	S	t	L	Stückgewicht Kg Unit weight Kg	Verpackung Packaging
43940050	110	3.2	61.5	126.5	0.26	320
43950050	125	3.2	61	127	0.37	240
43960050	160	3.6	65	135	0.65	115
43980050	200	4.0	78	163	1.35	60
43990050	250	5.5	118	250	1.90	32

HULIOT KG SYSTEM

PVC Kanalrohrsystem und Formstücke
Push-fit PVC Drainage pipes and fittings system



Formstücke / Fittings

■ KGU - Überschiebmuffe / KGU – Coupler

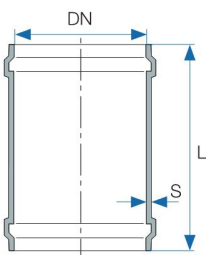

Art-nr. Art. No.	DN	S	L	Stückgewicht Kg Unit weight Kg	Verpackung Packaging
43940053	110	3.2	126.5	0.26	320
43950053	125	3.2	127	0.36	240
43960053	160	3.0	135	0.64	115
43980053	200	4.0	216	1.34	60

■ KGM Muffenstopfen / KGM – Plug

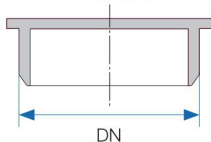

Art-nr. Art. No.	DN	Stückgewicht Kg Unit weight Kg	Verpackung Packaging
43840050	110	0.11	1000
43850050	125	0.15	600
43860050	160	0.28	300
43880050	200	0.56	224
43890050	250	1.15	96

■ KGK Kappe / KGK – Cap

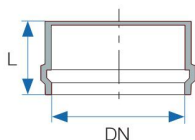

Art-nr. Art. No.	DN	L	Stückgewicht Kg Unit weight Kg	Verpackung Packaging
43840052	110	62	0.19	450
43850052	125	70	0.24	350
43860052	160	80	0.43	180
43880052	200	100	0.95	100
43890052	250	118	1.20	72



Formstücke / Fittings

■ Einfach-Rückstauverschluss / Single return water seal



Art-nr. Art. No.	DN	S	L1	L2	L3	H	Stückgewicht Kg Unit weight Kg	Verpackung Packaging
44040000	110	3.0	61	61	307	230	1.8	1
44050000	125	3.2	65	65	317	245	1.9	1
44060000	160	3.6	74	74	337	255	2.4	1
44080000	200	4.5	100	86	451	300	3.2	1

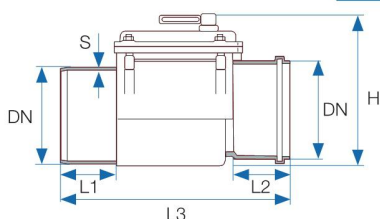

■ KGUG – Anschluss an Guss / KGUG – Connector to cast iron pipe



Art-nr. Art. No.	DN1	DN2	t1	t2	L	Stückgewicht Kg Unit weight Kg	Verpackung Packaging
42160050	160	176	80.0	13	245	0.59	90
42180050	200	230	80.3	16	220	0.91	25

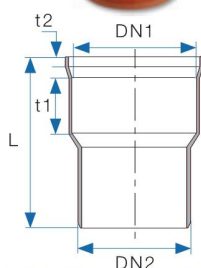

■ KGUS – Anschluss an Steinzeug Spitzende

KGUS – Connector to stoneware pipe seal



Art-nr. Art. No.	DN1	DN2	t1	t2	L	Stückgewicht Kg Unit weight Kg	Verpackung Packaging
44140040	140	110	-	-	67	0.22	325
44160040	185	160	80	13	248	0.27	270
44180040	230	200	80	16	260	0.435	135

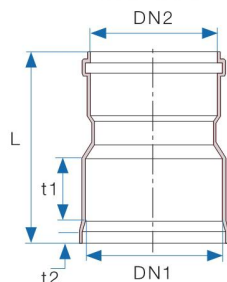

HULIOT KG SYSTEM

PVC Kanalrohrsystem und Formstücke
Push-fit PVC Drainage pipes and fittings system



Formstücke / Fittings

■ KGUS – Anschluss an Steinzeug Spitzende

KGUS – Connector to stoneware pipe seal

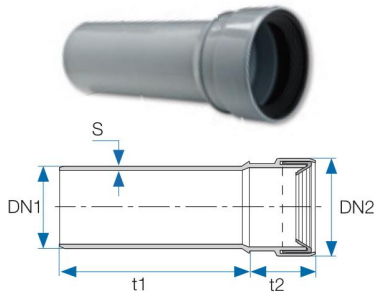

Art-nr. Art. No.	DN	Stückgewicht Kg Unit weight Kg	Verpackung Packaging
42140050	110	0.018	40/14000
42150050	125	0.026	40/4800
42160055	160	0.044	2/4480
42180055	200	0.066	3/9000
42190050	250	0.166	3/2400
42131050	315	0.236	2/1200

■ KGF S/B - Schachtfutter / KGF S/B – Chamber lining

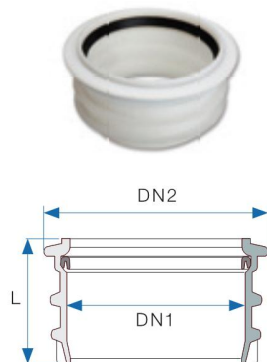

Art-nr. Art. No.	DN1	DN2	L	Stückgewicht Kg Unit weight Kg	Verpackung Packaging
44140040	110	140	67	0.22	325
44160040	160	196	86	0.27	270
44180040	200	239	103	0.435	135

Zubehör / Accessories

■ KG - Lippendichtung / KG – Lip seal

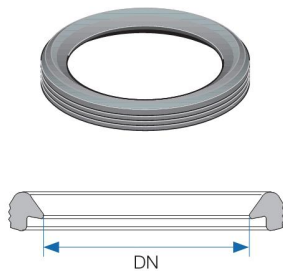

Art-nr. Art. No.	DN	Stückgewicht Kg Unit weight Kg	Verpackung Packaging
47640041	110	0.018	40/14000
47650041	125	0.026	40/4800
47660041	160	0.044	2/4480
47680041	200	0.066	3/9000
47690041	250	0.166	3/2400
47631541	315	0.236	2/1200
47649941	400	0.324	-



Tel : 77 77 24 25

HEATAIRCON

LTD

Tseriou 128 Ave,
2044 Nicosia, Cyprus

Tel : 00357 22314501
Fax : 00357 22312840

Email : info@heataircon.com.cy
Website : www.heataircon.com.cy



ADVANCED FLOW
SYSTEMS

HULIOT A.C.S Ltd.
Kibbutz Sde-Nehemia
Upper-Galile, 12145, ISRAEL
Tel: +972- 4-6946011, Fax: +972-4-6951444
info@huliot.com, www.huliot.com